		Operating manual Counting-, filling- and capping machine		Version: 1.0
				Author: DK
				Date: 2023-08-10
Com.-no.: 22.020	Project:	Counting-, filling- and capping line		
Document: BA - 22.022	Customer:			

1.2 Schematic view

1.2.1 Counting-, filling- and capping machine IBC 50 22.022

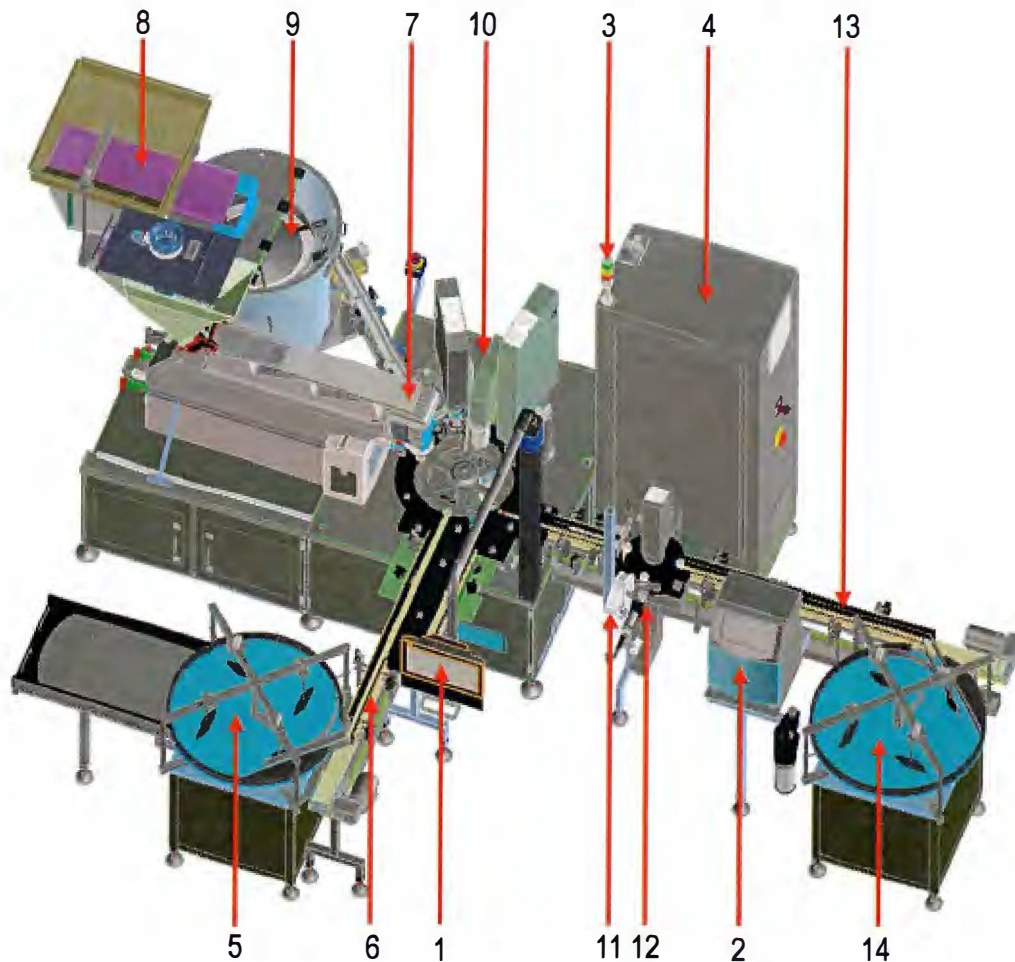

Example Image 1: Counting-, filling- and capping machine IBC 50

Pos.	Description
1	Control panel (HMI) with Emergency Stop switch
2	Control panel printer
3	Signal column
4	Control cabinet
5	Rotary table with manual container feed
6	Infeed conveyor
7	Tablet counting and filling station
8	Vibratory chute (Closures)
9	Vibratory sorting (Closures)
10	Closing station (Pre- and Re-torque / Sealing)
11	Cable holder for print head
12	Side print station with Reject area
13	Outfeed conveyor
14	Rotary table (Outfeed)

		Operating manual Counting-, filling- and capping machine		Version: 1.0
				Author: DK
				Date: 2023-08-10
Com.-no.:	22.020	Project:	Counting-, filling- and capping line	
Document:	BA - 22.022	Customer:		

1.3 Important machine/system specs and performance data

Size range:	Stable containers which can be accumulated, with a diameter up to 75 mm and a height from 40 up to 150 mm. Other dimensions upon request.
Output:	Adjustable up to 3000 containers/h, depending on container, kind and number of product per container and closure.
Filling station:	integrated Counting Module Type CF 622 with 6-counting channels. Counting module with the following features: <ul style="list-style-type: none"> - fully servomotor driven - 100% counting accuracy - Product hopper with 30 ltr. volume - counting, separating and product-reject (wrong-counts) in one device - connection for dust-extraction at the hopper- and middle vibratory plate - dipping nozzle system - 15" touch-screen-panel - Separate control with integrated Audit-Trail 21 CFR Part 11.
Kind of closures:	Round standard screw-caps
Standard control stations:	<ul style="list-style-type: none"> - Accumulation sensor at infeed and outfeed. - Presence of closure after closing station. - Overload-clutch for main-drive. - Maintenance unit for compressed air.
Control cabinet:	Made of polished V2A stainless steel. Positioned rear right side of the machine frame, behind the print station.
Control panel:	The panel is mounted on the right front side of the machine. It is rotatable.
Design:	The underframe is covered with stainless steel. The guarding's are made of security-glass. The frame of the guarding's is made of AISI 304 Doors with security switches.
Electrical supply:	230/400V, 50 Hz, 3 ph + N + PE (TN-S - Net)
Air-Supply:	6 bar, dry & oil free (Air quality according ISO 1217 of ISO 7183, air pressure dew point 3 °C, residual oil contents of 0,01 milligram/m ³ or less.)
PLC:	Siemens S7-series
Panel:	Touch-Screen-Panel
Working height:	900 +/- 25 mm
Working direction:	From left to right



Declaration of Conformity



Hereby declares:

Rudolf Deckert GmbH & Co. KG
Spezialmaschinen - Turn-Key Engineering
Steinbeisweg 60
D-74523 Schwäbisch Hall

That the construction of the plant:

Counting-, filling- and capping line

With the plant no.:

22.020

consisting of following components:

Machine designation	Manufacturer	Type	Com.-No.
Counting-, filling- and capping machine	R. Deckert	IBC 50	22.022
Rotary table (Infeed)	R. Deckert	DT 800	22.021
Vibratory sorting with Vibratory chute (Closures)	R. Deckert	VSS 550	22.025
Rotary table (Outfeed)	R. Deckert	DT 800	22.028

due to its design and construction and in the version delivered by us, complies with the relevant basic safety and health requirements of the EC Machinery Directive. In the case of a modification of the machine that has not been agreed with us, this declaration loses its validity.



Version:	1.0
Author:	DK
Date:	2023-08-10

The following standards, directives and specifications were applied:

EU-Machinery directive: 2006/42/EC

EU-Low voltage directive: 2014/35/EU

EU-Pressure Equipment Directive: 2014/68/EU

EU-Directive Electromagnetic Compatibility: 2014/30/EU

National technical specifications used, in particular: DGUV V3

Applied harmonized norms, especially: DIN EN ISO 12100
DIN EN 60204-1

Date / Signature:

10. AUG. 2023

Information from the signatory:

Michael Mall (Plant management)
Rudolf Deckert GmbH & Co. KG

		Type Plates Counting-, filling- and capping line		Version: 1.0
				Author: DK
				Date: 2023-08-10
Com.-no.: 22.020	Project:	Counting-, filling- and capping line		
Document: TYS - 22.020	Customer:			

6.3 Specific type plates

6.3.1 Counting-, filling- and capping machine

Maschinen-Nr./Machine No.		Baujahr / Year of Construction	
22.022		2023	
Typ / Type			
IBC 50			
Nennspannung V / Nominal Voltage V			
400V, 3/N/PE, 50Hz			
Steuerspannung V / Control Voltage V		Leistung kVA / Rated Power kVA	
24 VDC		12,9	
Schaltplan-Nr. / Wiring Diagram No.			
22_020			

6.3.2 Rotary table (Infeed)

Maschinen-Nr./Machine No.		Baujahr / Year of Construction	
22.021		2023	
Typ / Type			
DT 800			
Nennspannung V / Nominal Voltage V			
Steuerspannung V / Control Voltage V		Leistung kVA / Rated Power kVA	
Schaltplan-Nr. / Wiring Diagram No.			
22_020			

6.3.3 Vibratory sorting with Vibratory chute (Closures)

Maschinen-Nr./Machine No.		Baujahr / Year of Construction	
22.025		2023	
Typ / Type			
VSS 550			
Nennspannung V / Nominal Voltage V			
Steuerspannung V / Control Voltage V		Leistung kVA / Rated Power kVA	
Schaltplan-Nr. / Wiring Diagram No.			
22_020			

		Type Plates Counting-, filling- and capping line		Version: 1.0
				Author: DK
				Date: 2023-08-10
Com.-no.:	22.020	Project:	Counting-, filling- and capping line	
Document:	TYS - 22.020	Customer:		

6.3.4 Rotary table (Outfeed)

Maschinen-Nr./Machine No.		Baujahr / Year of Construction	
22.028		2023	
Typ / Type			
DT 800			
Nennspannung V / Nominal Voltage V			
Steuerspannung V / Control Voltage V		Leistung kVA / Rated Power kVA	
Schaltplan-Nr. / Wiring Diagram No.			
22_020			

EC Declaration of Conformity



In accordance with Annex II 1 A of the Machine Directive 2006/42/EC

Manufacturer and holder of the Technical Construction File

Cremer Speciaal machines B.V.
Heereweg 5
2161 AB Lisse
Holland

Machine identification

Description	Counting module
Project number	31729
Model	CF 622
Serial number(s)	31729.009
Date of manufacturing	09-2022

The manufacturer declares that the machine meets the essential conditions set out in the following EC directives:

- 2006/42/EC Machine Directive
- 2014/35/EU Low Voltage Directive
- 2014/30/EU Electromagnetic Compatibility Directive

For the above directives the following harmonized standards are applied:

- EN-ISO 12100:2010
- EN 60204-1:2006/A1:2009

The machine(s) covered by this EC Declaration of Conformity must not be put into service until the machinery into which it is to be incorporated has been declared in conformity with the provisions of the applicable directives.

Signed for Cremer Speciaal machines B.V.

M. van der Wolf
Managing director

September 15, 2022



CREMER

UHLMANN GROUP

Einleitung

Dieses Kapitel beschreibt die allgemeine Funktionsweise des Zähl- und Abfüllsystems und zeigt und beschreibt alle wichtigen Einzelheiten und Bedienelemente. Alle Personen die wahrscheinlich in der Bedienung und Wartung des Zähl- und Abfüllsystems beschäftigt sind sollten eine entsprechende Ausbildung zu allen mitgelieferten Informationen in diesem Kapitel absolviert haben.

Maschinenbeschreibung und bestimmungsgemäße Benutzung

Das Cremer CFF 622x1 Zähl- und Abfüllsystem ist speziell zum separieren und zählen von Tabletten, Kapseln, Gel-Kapseln oder Caplets (im Folgenden als "Produkte" genannt) konstriert und abfüllen der vorher eingestellten Stückzahl durch einen "senkenden" Füllstutzen in Glas- oder Kunststoffflaschen oder anderen Behältnissen.

Das Zähl- und Abfüllsystems ist für den ausschließlichen Betrieb in Übereinstimmung mit dem Vertrag oder der Auftragsbestätigung bestimmt. Jede andere oder weitere Verwendung der Maschine (z. B. die Verarbeitung von Produkten oder Flaschen oder anderen Behältnissen) die nicht im Vertrag oder der Auftragsbestätigung sind gegen die technische Entwurfs- Spezifikation. Der Hersteller übernimmt keine Verantwortung für Schäden an der Maschine oder Personenschaden, die aus entgegensätzlichen Nutzung zu dieser Spezifikation entstehen.

Generelle Übersicht - CFF 622x1 Zähl- und Füllsystem

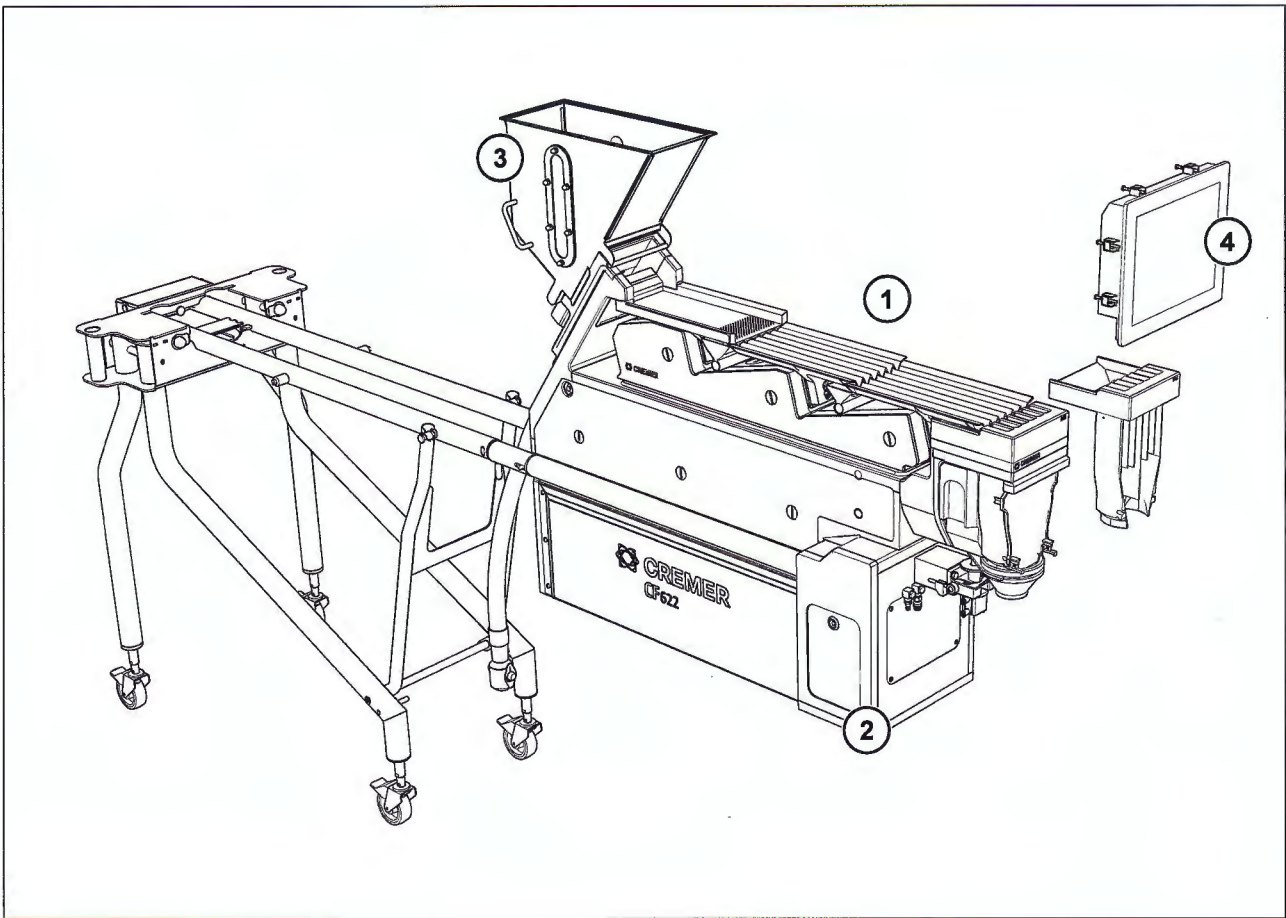

Das CFF 622x2 Zähl- und Füllsystem besteht im wesentlichen aus:

- 1 1x CF 622 Zählmodul
- 2 1x CFF 622x1 Tragrahmen
- 3 1x Vorratstrichter
- 4 1x Touchscreen Bedienfeld

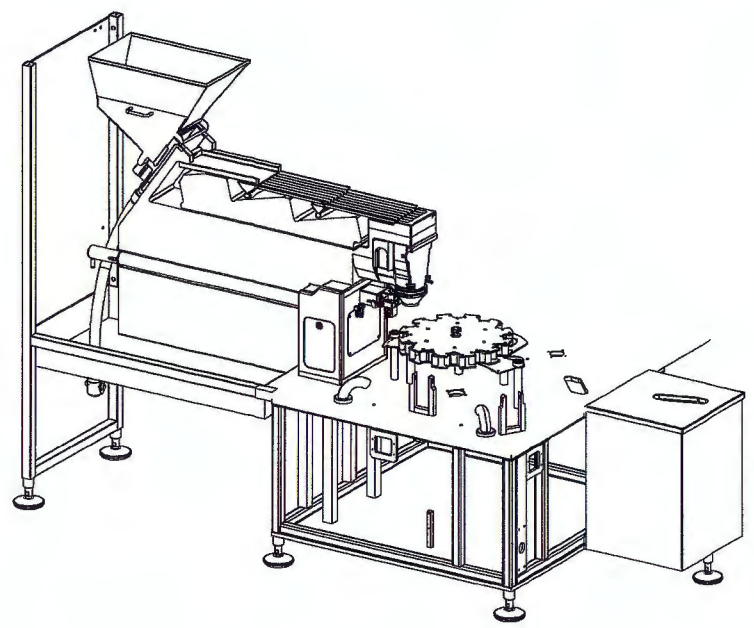
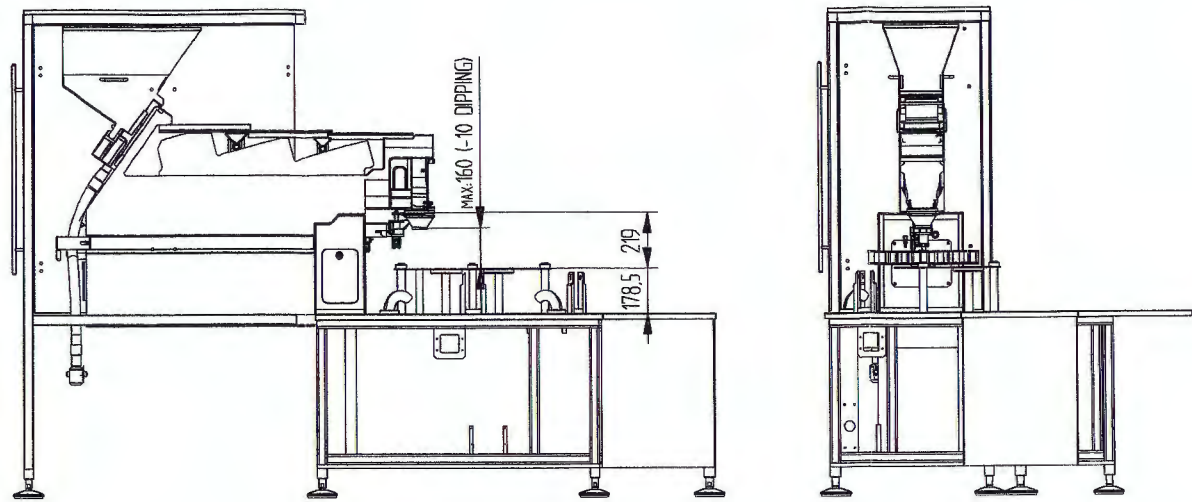

CREMER CFF-622X1 MONOBLOCK

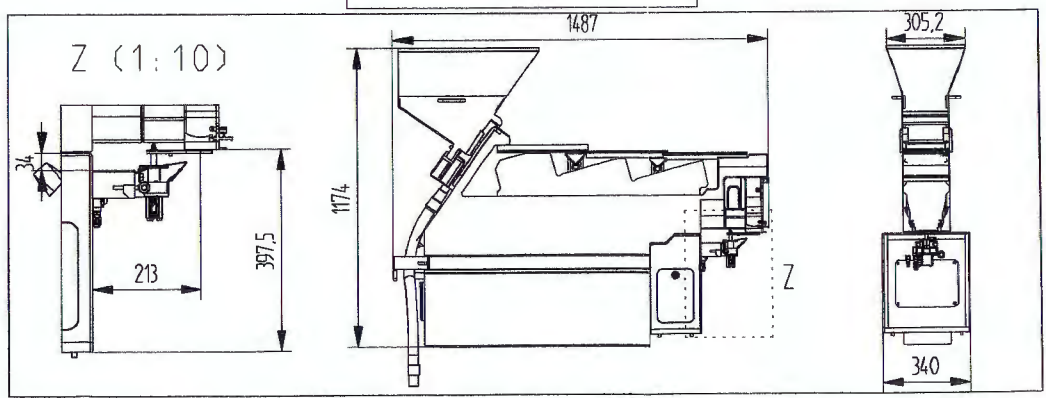

Oppervlaktebehandeling

CREMER
HEEREWEG 5A, 2161 AB LISSE - THE NETHERLANDS



Schaal: 1:20
Bestandsnaam: C:FGCA03BE.SZA

Dit document is eigendom van Cremer Sneltestmachines B.V. Lisse, Holland.
Reproductie en/of bekendmaking van dit document of delen daarvan, van dien aard, is
alleen toegestaan met schriftelijke toestemming van Cremer Sneltestmachines B.V.

Revisie	Wijziging	Datum	Naam
06	Zie index revisie in HELIOS		
07	Zie index revisie in HELIOS	Getekend	10.11.2022 van Bezu
06	Zie index revisie in HELIOS	Gecont.	23.11.2020 van Bezu
05	Zie index revisie in HELIOS		
04	Zie index revisie in HELIOS		
03	Zie index revisie in HELIOS		
02	Zie index revisie in HELIOS		
01	Zie index revisie in HELIOS		

Tekeningstijl: OVERZICHT MACHINE
CFF-622X1 MONOBLOCK

Tenzij anders vermeld
Afmetingen in mm ±0.5
Oppervlakte ruwheid
Hoeken ≤ 7°
Laser ±0.1

Tekeningnummer: 32622.0001
Revisie: 00
Formaat: A3

